



ROSCAMAT®

ROSCADOR ELECTRICO REF DRAGON DE BRAZO ROSCAMAT CAPACIDAD DE ROSCADO **M2-M27 (M30)**



Calle 85A No. 28C-16 Bogotá D.C. Colombia
Barrio Polo Club. Bogotá. PBX. 2564252.

www.servitoolsas.com

info@servitoolsas.com



ROSCAMAT®



Tapping Capacity : M2-M27 (M30)

We can consider the usage of the machine R-Dragon identical to the R-Tiger, but with the advantage of having much more working area, because of the length of the arms.

The machine consist of a radial supporting both articulated arms that can be adjusted by means of hte regulation handwheels to position them at the operator's convenience

The multiposition head is a double swivel joint device allowing to lock and unlock both swivel pins to thus position the head and keep it blocked in order to thus operate in any space position.

Through the base by three M8 screws the machine can be fixed to a table or workbench. Such attachment can also be obtained by means of a simple clamp.

Link de video youtube en funcionamiento:

<https://youtu.be/yxdy4j0Do3o>

<https://youtu.be/hETauVtlHk8>

Calle 85A No. 28C-16 Bogotá D.C. Colombia
Barrio Polo Club. Bogotá. PBX. 2564252.
www.servitoolsas.com
info@servitoolsas.com



ROSCAMAT®



Electric motor

High Frequency Electric motor. Power 0,55 Kw. Single phase (220V or 110). Motor supply voltage: 200-240 V. 50/60 Hz. Less speed: 90 rpm – Highest speed: 2.100 rpm



Tapping System RH (RHC)

To work in any space positions therewith always maintaining the perpendicularity to the work plane regardless the arm position.

Calle 85A No. 28C-16 Bogotá D.C. Colombia
Barrio Polo Club. Bogotá. PBX. 2564252.
www.servitoolsas.com
info@servitoolsas.com



AREA DE TRABAJO:

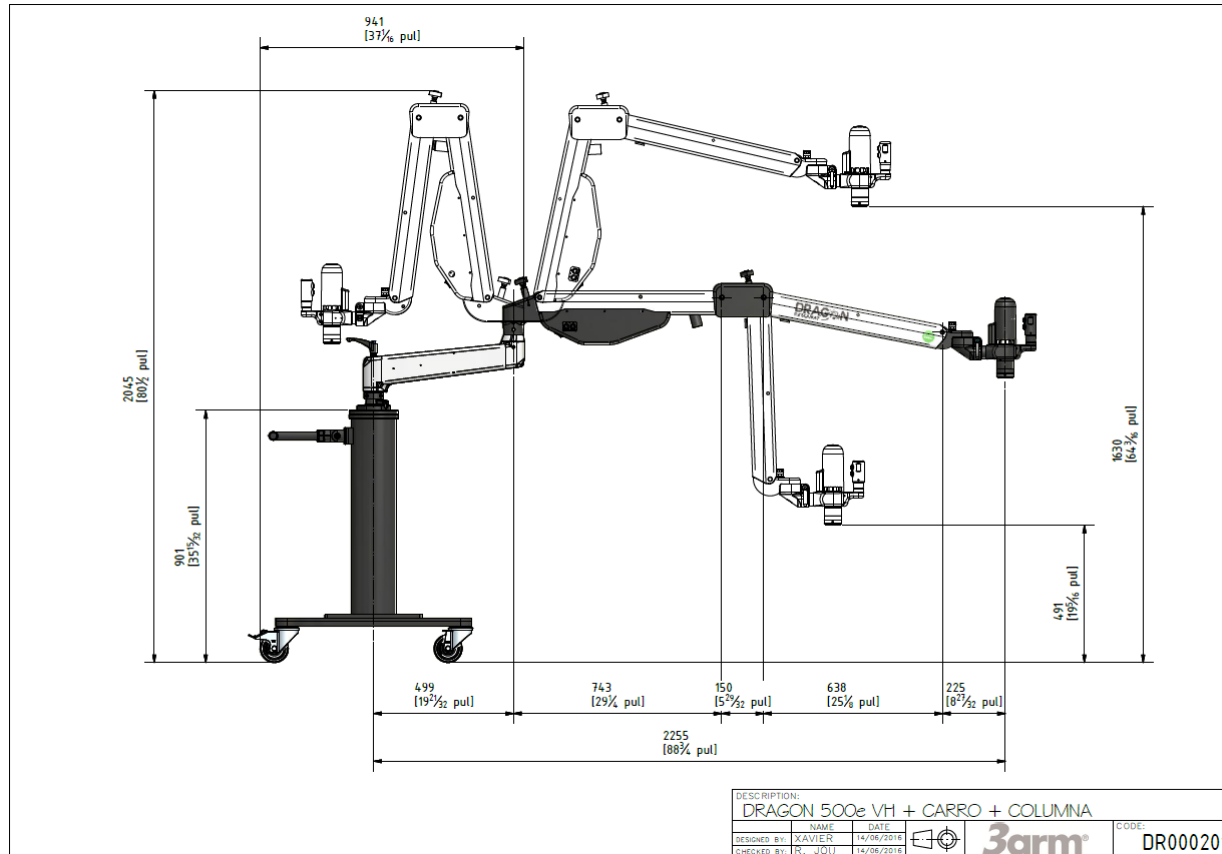

Calle 85A No. 28C-16 Bogotá D.C. Colombia
 Barrio Polo Club. Bogotá. PBX. 2564252.

www.servitoolsas.com
info@servitoolsas.com



ACCESORIOS:



Quick-change Toolholders

A wide range of tapholders, all of them with or without clutch, apart from other quick holding fixture for different tools, such as drills, sinking tools, threading dies, socket wrenches, etc. are available. **Tapholder with safety clutch** so that it slips when it reaches the hole bottom. Type 1 Ø19 mm: capacity range M2-M16 (for modules 900, 500, 320) Type 2 Ø31 mm: capacity range M6-M30 (for modules 140 & 75) Type 3 Ø48 mm: capacity range M14-M42 (for module 40) **Tapholder without safety clutch** for holding different tools with cylindrical shank and driving cube. Type 1 Ø19 mm: capacity range M2-M16 (for modules 900, 500, 320) Type 2 Ø31 mm: capacity range M6-M30 (for modules 140 & 75) Type 3 Ø48 mm: capacity range M14-M42 (for module 40)



Calle 85A No. 28C-16 Bogotá D.C. Colombia
Barrio Polo Club. Bogotá. PBX. 2564252.
www.servitoolsas.com
info@servitoolsas.com



ACCESORIOS:



Modular System

The modular system provides for a new concept in the use of articulated tapping arm machines. Driven from a single motor, seven different speed modules are available with their relevant power torques. The seven quick-change speed modules provide the speed and torque for each threading type, from M2 to M27 (M33) threads.

Module	Max. Speed (rpm)	Max. Torque (Nm)	Coupling diameter	Max. Thread Aluminium Cast Irons	Max Thread Steel .
90	90	150	Ø 31	M30 - 1 /1/8"	M27 - 1 "
170	170	79	Ø 31	M24 - 7/8"	M20 - 3/4"
300	300	44	Ø 19	M16 - 9/16"	M16 - 9/16"
550	550	24	Ø 19	M14 - 1/2"	M12 - 7/16"
750	750	17	Ø 19	M12 - 7/16"	M10 - 3/8"
1050	1050	12.5	Ø 19	M8 - 5/16"	M8 - 5/16"
2100	2100	6	Con B-16	To drill up to Ø 8 Aluminium, brass, etc.	

Calle 85A No. 28C-16 Bogotá D.C. Colombia
Barrio Polo Club. Bogotá. PBX. 2564252.

www.servitoolsas.com
info@servitoolsas.com



ROSCAMAT®

ACCESORIOS:



Automatic tap lubrication (OPTIONAL)

AUTOMATIC TOOL LUBRICATION: The "automatic thread lubrication system" is attached to the lower part of the radial arm. If it is not preinstalled on the machine, it can be attached later. The lubrication time is counted in seconds and adjusted using the potentiometer on the upper part of the radial arm.

Calle 85A No. 28C-16 Bogotá D.C. Colombia
Barrio Polo Club. Bogotá. PBX. 2564252.

www.servitoolsas.com
info@servitoolsas.com