



ROSCAMAT®

ROSCADOR ELECTRICO REF SHARK DE BRAZO ROSCAMAT CAPACIDAD DE ROSCADO **M3-M36 (M42)**



Calle 85A No. 28C-16 Bogotá D.C. Colombia
Barrio Polo Club. Bogotá. PBX. 2564252.

www.servitoolsas.com

info@servitoolsas.com



ROSCAMAT®



Capacity M3-M36 (M42)

The machine is formed by a tilting arm being by means of a pneumatic spring, said arm being fitted through an intermediary union to a radial arm being revolvable around 360°. The assembly is secured to the workbench by means of a base plate being provided with a post clearing the whole table area.

The motor head finds itself at the end of the tilting arm and is apt to always move at right angles with respect to its working area.

The *motor speed*, the *tool automatic lubrication* and the *depth control* can be adjusted by means of a display placed on the cover of the electronic board case.

Link de video youtube en funcionamiento:

<https://www.youtube.com/watch?v=Adk1eThv3oo>

<https://www.youtube.com/watch?v=LqQHimlWQdE>

Calle 85A No. 28C-16 Bogotá D.C. Colombia
Barrio Polo Club. Bogotá. PBX. 2564252.
www.servitoolsas.com
info@servitoolsas.com

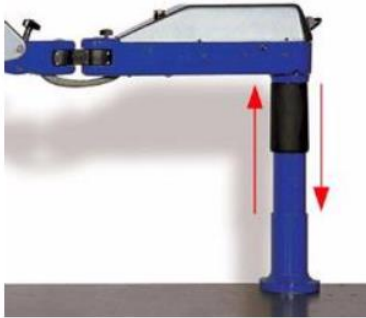

Lifter

The working height of the machine can be increased by 160 mm. in order to thus be in a position to work at different heights.



Electric motor

High Frequency Electric motor. Power 1,5 Kw. Single phase (220V or 110). Motor supply voltage: 200-240 V. 50/60 Hz. Less speed: 40 rpm – Highest speed: 900 rpm



VH

The ROSCAMAT SHARK VH (Vertical & Horizontal, 4x90°) includes an easily-handled articulated head assembly that allows the motor to be positioned in four 90° positions and tap in horizontal and vertical direction.

Calle 85A No. 28C-16 Bogotá D.C. Colombia
Barrio Polo Club. Bogotá. PBX. 2564252.

www.servitoolsas.com

info@servitoolsas.com

AREA DE TRABAJO:

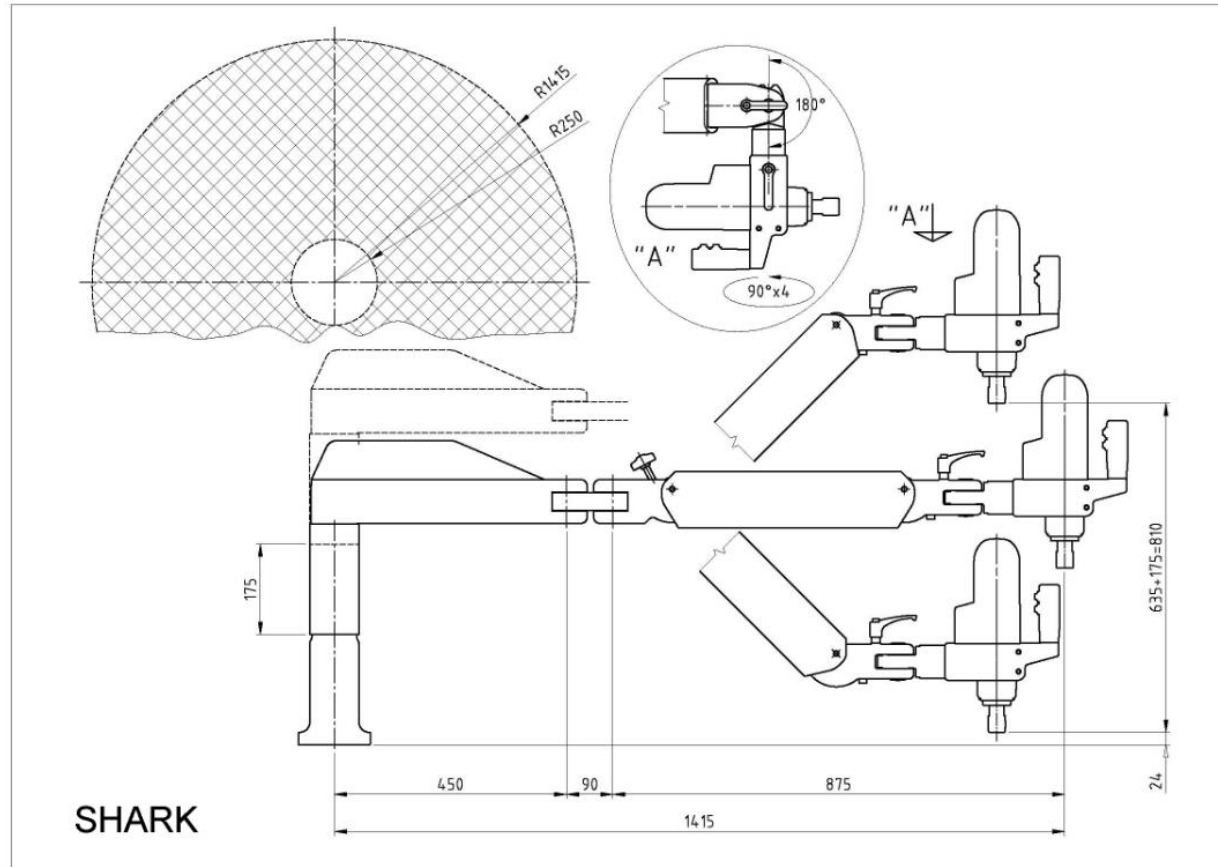

Calle 85A No. 28C-16 Bogotá D.C. Colombia
Barrio Polo Club. Bogotá. PBX. 2564252.

www.servitoolsas.com

info@servitoolsas.com

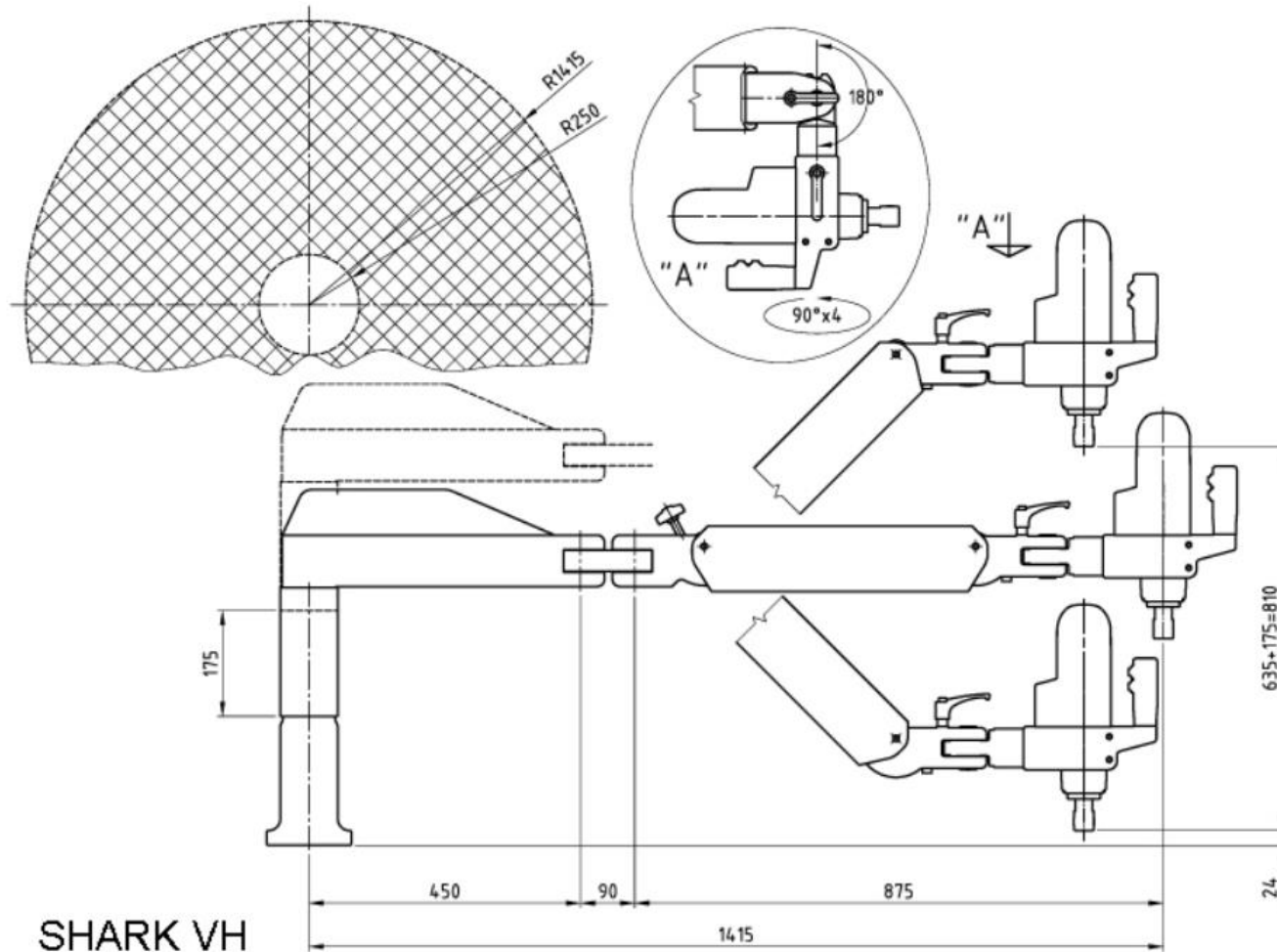

SHARK VH

Calle 85A No. 28C-16 Bogotá D.C. Colombia
Barrio Polo Club. Bogotá. PBX. 2564252.

www.servitoolsas.com

info@servitoolsas.com



ACCESORIOS:



Cambio rápido portaherramientas

Están disponibles un amplio surtido de portamachos, todos ellos con o sin embrague a parte de otros porta herramientas de sujeción rápida como brocas, avellanadores, terrajas, llaves de vaso, etc. **Los portamachos con embrague de seguridad** hace que patine el macho cuando llega al fondo del agujero. El tipo 1 Ø19 mm tiene capacidad de M2 a M16 (para módulos 1050, 750, 550 y 300 rpm). El tipo 2 Ø31 mm tiene capacidad de M6 a M30 (para módulos 170 y 90 rpm). **El portamachos sin embrague de seguridad** pueden sujetar diferentes herramientas de mango cilíndrico y cuadro de arrastre. El tipo 1 Ø19mm tiene capacidad de M2 a M16 (módulos 1050,750,550,300 rpm). El tipo 2 Ø31 mm tiene capacidad de M6 a M30 (para módulos 170 y 90 rpm).



Calle 85A No. 28C-16 Bogotá D.C. Colombia
Barrio Polo Club. Bogotá. PBX. 2564252.

www.servitoolsas.com

info@servitoolsas.com



Modular system

The **modular system** is apt to be fitted to the electronic motor and consists of a 6 quick-change planetary speed reducers giving 6 different speeds and torques. The speed can be thus adapted to every thread type.

Module	Max. Speed (rpm)	Max. Torque (Nm)	Coupling Diameter	Max. Thread Aluminium Cast Irons	Max Thread Steel .
40	40	340	Ø 48	M42 – 1 1/2"	M36 – 1 1/4"
75	75	185	Ø 31	M33 – 1 1/4"	M27 – 1"
140	140	95	Ø 31	M27 – 1"	M22 – 7/8"
320	310	44	Ø 19	M20 – 3/4"	M16 - 9/16"
500	480	28	Ø 19	M16 – 9/16"	M12 - 7/16"
900	900	15	Ø 19	M10 – 3/8"	M8 - ;5/16"

Calle 85A No. 28C-16 Bogotá D.C. Colombia
 Barrio Polo Club. Bogotá. PBX. 2564252.

www.servitoolsas.com

info@servitoolsas.com



ROSCAMAT®



Automatic Tap Lubrication

Inside the radial arm the cutting oil reservoir is located. This is used for lubricating the tool during the tapping operation. The lubrication time according to the metric size to be done is adjusted by means of one of the upper head buttons.



Depth control

By means of an internal system, the machine controls **the vertical arm position** (Axe Z) in mm. so that you can control at which desired depth you wish to tap.

Calle 85A No. 28C-16 Bogotá D.C. Colombia
Barrio Polo Club. Bogotá. PBX. 2564252.
www.servitoolsas.com
info@servitoolsas.com