

NPU



Portabrocas de autoapriete de precisión con cono integrado

- Para máquinas CNC y fresadoras.
- La única unión mediante el cono morse del portabrocas al mango elimina espigas intermedias y asegura una máxima rigidez y precisión.
- Se suministra con dos ranuras fresadas en el cuerpo del portabrocas y una llave para aplicar un par de apriete suplementario.
- Impide el desprendimiento de la herramienta en máquinas de alta velocidad y parada instantánea del eje.
- Excentricidad máxima de 0,04 mm.



Ventajas

NPU13 - ID40

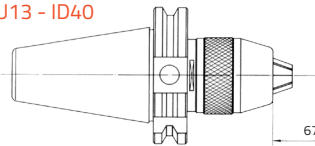

Mango no integral

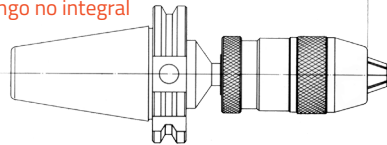

1. Construcción más compacta

El portabrocas SPX-13 con mango DIN-69871 ISO 40 es 67 mm. más largo que el NPU-13 con el mismo mango. Mayor longitud implica mayor posibilidad de excentricidad.

2. Mayor precisión

La excentricidad se controla en relación al cono de fijación a la máquina y no se necesita un mandrino intermedio, como es el caso de los portabrocas tradicionales.

3. Tornillo tirante

La unión entre el cono interior del mango y el cono interior del portabrocas es perfecta y garantizada, mediante un tornillo tirante.

4. Máxima rigidez en la unión

La unión del portabrocas al mango mediante un cono MORSE corto es mejor que con conos DIN o JACOBS, por rigidez, longitud y precisión.



5. Ventajas del apriete con llave

Par de apriete hasta 3 veces superior.

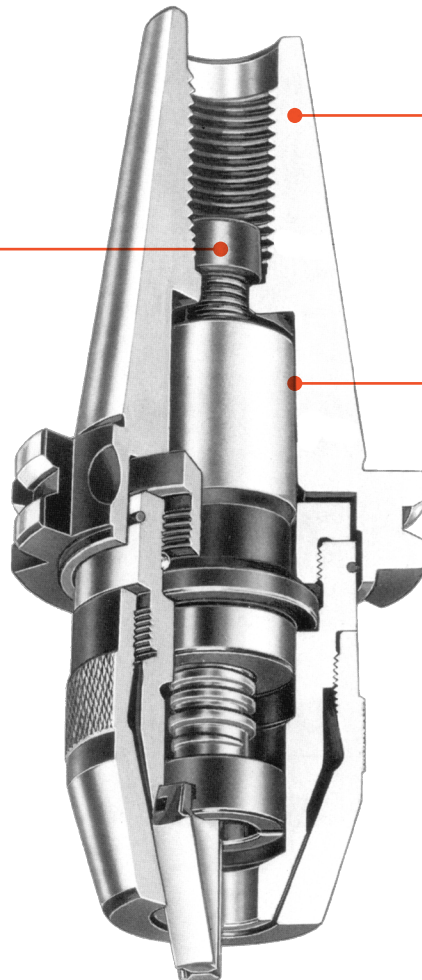

Portabrocas 0-3 mm. y 0-6,5 mm. disponibles bajo demanda para todos los modelos NPU

REFERENCIA	CAPACIDAD		CONO	DIMENSIONES				ROSCA	PESO
	número	mm		pulgadas	fijación	∅	L1		
NPU-08 ID 30	0,3 - 8	1/64" - 5/16"	30	38	77	83	-	M12	1,10
NPU-08 ID 40	0,3 - 8	1/64" - 5/16"	40	38	70	76	-	M16	1,50
NPU-08 ID 40/110	0,3 - 8	1/64" - 5/16"	40/110	38	110	116	-	M16	1,95
NPU-10 ID 30	0,5 - 10	1/32" - 3/8"	30	43	86	94	-	M12	1,30
NPU-10 ID 40	0,5 - 10	1/32" - 3/8"	40	43	74	82	-	M16	1,60
NPU-10 ID 40/110	0,5 - 10	1/32" - 3/8"	40/110	43	114	122	-	M16	1,95
NPU-13 ID 40	1 - 13	1/32" - 1/2"	40	48	80	91	-	M16	1,70
NPU-13 ID 40/125	1 - 13	1/32" - 1/2"	40/125	48	130	141	-	M16	2,45
NPU-13 ID 45	1 - 13	1/32" - 1/2"	45	48	78	89	-	M20	2,50
NPU-13 ID 50	1 - 13	1/32" - 1/2"	50	48	78	89	-	M24	3,65
NPU-16 ID 40	3 - 16	1/8" - 5/8"	40	55	97	108	-	M16	2,15
NPU-16 ID 50	3 - 16	1/8" - 5/8"	50	55	76	89	-	M24	3,75
NPU-16 ID 50/125	3 - 16	1/8" - 5/8"	50/125	55	130	140	-	M24	4,90
NPU-08 BT 30	0,3 - 8	1/64" - 5/16"	30	38	73	79	-	M12	1,10
NPU-08 BT 40	0,3 - 8	1/64" - 5/16"	40	38	78	84	-	M16	1,50
NPU-08 BT 40/110	0,3 - 8	1/64" - 5/16"	40/110	38	78	84	-	M16	1,90
NPU-10 BT 30	0,5 - 10	1/32" - 3/8"	30	43	89	97	-	M12	1,30
NPU-10 BT 40	0,5 - 10	1/32" - 3/8"	40	43	79	87	-	M16	1,70
NPU-10 BT 40/110	0,5 - 10	1/32" - 3/8"	40/110	43	109	117	-	M16	2,10
NPU-13 BT 40	1 - 13	1/32" - 1/2"	40	48	86	97	-	M16	1,90
NPU-13 BT 40/130	1 - 13	1/32" - 1/2"	40/130	48	136	147	-	M16	2,70
NPU-13 BT 50	1 - 13	1/32" - 1/2"	50	48	97	108	-	M24	4,60
NPU-16 BT 40	3 - 16	1/8" - 5/8"	40	55	105	116	-	M16	2,30
NPU-16 BT 50	3 - 16	1/8" - 5/8"	50	55	95	106	-	M24	4,70
NPU-16 BT 50/145	3 - 16	1/8" - 5/8"	50/145	55	145	156	-	M24	5,80
NPU-08 DIN 30	0,3 - 8	1/64" - 5/16"	30	38	70	76	-	M12	1,00
NPU-08 DIN 40	0,3 - 8	1/64" - 5/16"	40	38	63	69	-	M16	1,40
NPU-10 DIN 30	0,5 - 10	1/32" - 3/8"	30	43	77	85	-	M12	1,20
NPU-10 DIN 40	0,5 - 10	1/32" - 3/8"	40	43	72	80	-	M16	1,60
NPU-13 DIN 40	1 - 13	1/32" - 1/2"	40	48	78	89	-	M16	1,70
NPU-13 DIN 50	1 - 13	1/32" - 1/2"	50	48	90	101	-	M24	3,60
NPU-16 DIN 40	3 - 16	1/8" - 5/8"	40	55	90	101	-	M16	2,10
NPU-16 DIN 50	3 - 16	1/8" - 5/8"	50	55	72	83	-	M24	3,75
NPU-08 CA 30-A	0,3 - 8	1/64" - 5/16"	30	38	101	107	-	1/2"-13	0,85
NPU-08 CA 40-A	0,3 - 8	1/64" - 5/16"	40	38	82	88	-	5/8"-11	1,30
NPU-13 CA 40-A	1 - 13	1/32" - 1/2"	40	48	115	126	-	5/8"-11	1,85
NPU-13 CA 45-A	1 - 13	1/32" - 1/2"	45	48	96	107	-	3/4"-10	2,25
NPU-13 CA 50-A	1 - 13	1/32" - 1/2"	50	48	96	107	-	1"-8	2,50
NPU-16 CA 40-A	3 - 16	1/8" - 5/8"	40	55	120	131	-	5/8"-11	3,65
NPU-16 CA 50-A	3 - 16	1/8" - 5/8"	50	55	94	105	-	1"-8	3,85
NPU-08 VDI 30	0,3 - 8	1/64" - 5/16"	30	38	72	79	-	-	1,85
NPU-13 VDI 30	1 - 13	1/32" - 1/2"	30	48	94	105	-	-	2,10
NPU-13 VDI 40	1 - 13	1/32" - 1/2"	40	48	85	92	-	-	2,40
NPU-16 VDI 40	3 - 16	1/8" - 5/8"	40	55	85	96	-	-	2,60
NPU-16 VDI 50	3 - 16	1/8" - 5/8"	50	55	87	98	-	-	2,65
NPU-16 VDI 60	3 - 16	1/8" - 5/8"	60	55	87	98	-	-	5,40
NPU-08 CIL 25	0,3 - 8	1/64" - 5/16"	25	38	66	73	56	-	0,85
NPU-08 CIL 30	0,3 - 8	1/64" - 5/16"	30	38	66	73	56	-	1,30
NPU-08 CIL 32	0,3 - 8	1/64" - 5/16"	32	38	66	73	56	-	1,85
NPU-13 CIL 32	1 - 13	1/32" - 1/2"	32	48	80	92	65	-	2,25
NPU-13 CIL 40	1 - 13	1/32" - 1/2"	40	48	80	92	65	-	2,50
NPU-16 CIL 40	3 - 16	1/8" - 5/8"	40	55	84	96	70	-	3,65
NPU-16 CIL 50	3 - 16	1/8" - 5/8"	50	55	84	96	70	-	3,85
NPU-13 HSK 50	1 - 13	1/32" - 1/2"	50	48	120	131	-	-	2,10
NPU-13 HSK 63	1 - 13	1/32" - 1/2"	63	48	120	131	-	-	2,30
NPU-16 HSK 63	3 - 16	1/8" - 5/8"	63	55	131	142	-	-	2,65
NPU-16 HSK 80	3 - 16	1/8" - 5/8"	80	55	134	145	-	-	3,40
NPU-16 HSK 100	3 - 16	1/8" - 5/8"	100	55	134	145	-	-	4,40
NPU-03 B	0,3 - 3	1/64" - 1/8"	B-12	24	38	41	-	-	0,12
NPU-06 B	0,3 - 6,5	1/64" - 1/4"	B-18	33	52	59	-	-	0,28
NPU-08 B	0,3 - 8	1/64" - 5/16"	B-18	38	57	64	-	-	0,38
NPU-10 B/30 ⁽¹⁾	0,5 - 10	1/32" - 3/8"	B-18	43	64	74	-	-	0,54
NPU-010 B/40 ⁽²⁾	0,5 - 10	1/32" - 3/8"	B-18	43	64	74	-	-	0,54
NPU-13 B	1 - 13	1/32" - 1/2"	MORSE-3	48	72	84	-	-	0,76
NPU-16 B/40 ⁽²⁾	3 - 16	1/8" - 5/8"	MORSE-3	54	76	88	-	-	1,06
NPU-16 B/50 ⁽³⁾	3 - 16	1/8" - 5/8"	MORSE-3	54	76	88	-	-	1,06

⁽¹⁾ para conos 30 ⁽²⁾ para conos 40 ⁽³⁾ para conos 50

DIN-69871-A

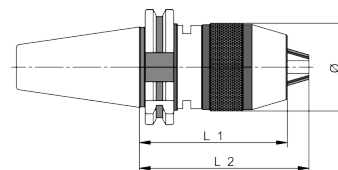

MAS 403-BT [JIS-6339A]

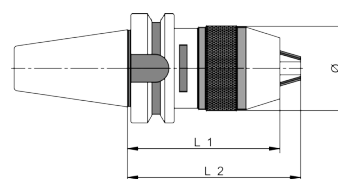

DIN-2080

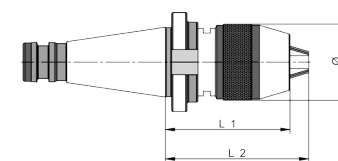

CAT-ANSI

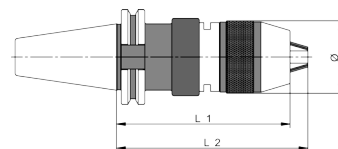

DIN-69880 VDI 3425/2

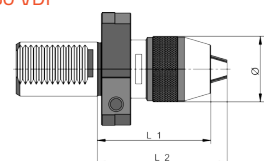

CILÍNDRICO

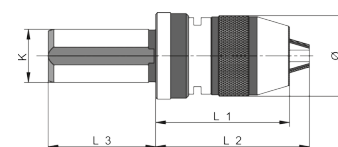

DIN-69893-A [HSK]

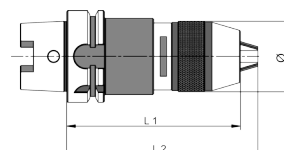

NPU-B

